

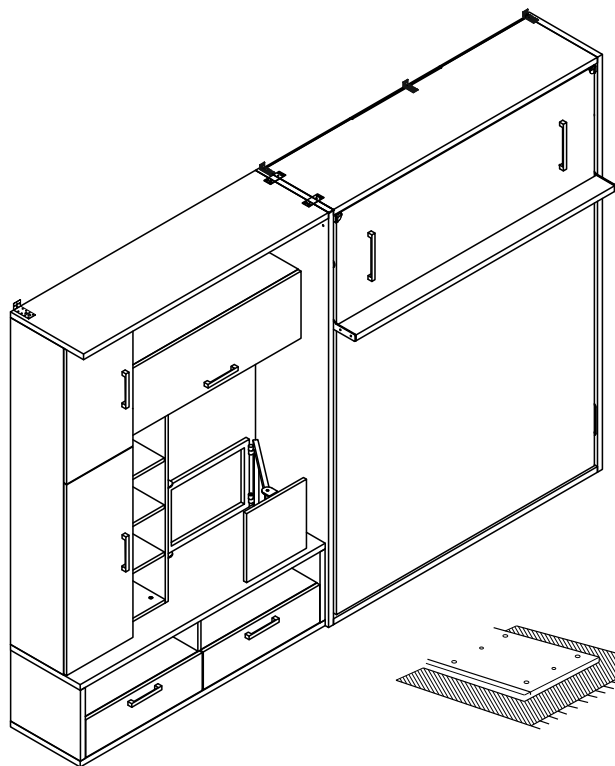

MULTIMO

161- SALOON NEW



100min.



Technical Service



220min.



End User

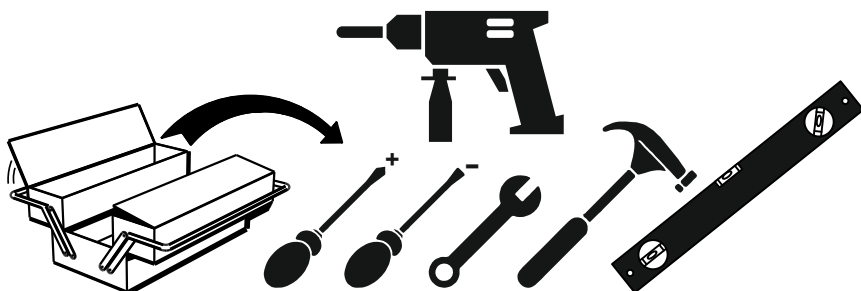
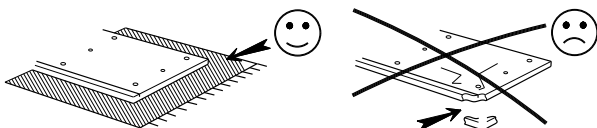

VIDEO

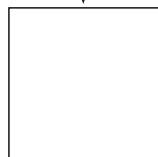









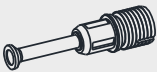

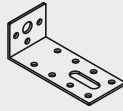
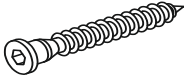

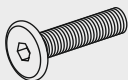

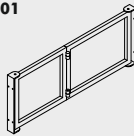



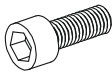

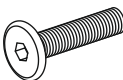
link

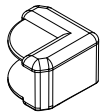
Assembly Instructions

Track Title	Piece	(inch)			(mm)			
		Thickness	Length	Width	Piece	Thick	Height	Most
A	1	57,32	16,54	1,18	1	1456	420	30
B (R-L)	2	81,89	17,32	0,71	2	2080	440	18
C	1	57,32	17,32	1,18	1	1456	440	30
D	2	57,32	5,91	0,71	2	1456	150	18
E	1	57,32	4,33	1,18	1	1456	110	30
F	1	58,11	17,32	0,71	1	1476	440	18
G (R-L)	2	63,78	12,60	0,71	2	1620	320	18
H	2	14,33	12,60	0,71	2	364	320	18
I	1	14,33	11,81	0,71	1	364	300	18
J	3	14,33	11,02	0,71	3	364	280	18
K	2	12,36	10,24	0,71	2	314	260	18
L	2	42,28	10,24	0,71	2	1074	260	18
M	1	58,19	16,54	16,93	1	1478	420	430
N (R-L)	2	39,37	9,84	0,71	2	1000	250	18
O	2	10,39	9,84	0,71	2	264	250	18
P	2	10,39	8,86	0,71	2	264	225	18
R	1	24,25	15,67	0,71	1	616	398	18
S	1	39,17	15,67	0,71	1	995	398	18
T	1	42,05	14,17	0,71	1	1068	360	18
U	1	78,54	56,46	0,71	1	1995	1434	18
Y	1	10,39	8,86	0,71	1	264	225	18
Z	1	9,84	5,71	0,71	1	250	145	18
X-1	3	81,06	7,48	0,31	3	2057	489	8
X-2	1	63,03	15,00	0,31	1	1601	381	8
X-3	1	41,54	13,03	0,31	1	1055	331	8
X-4	1	38,58	11,02	0,31	1	980	280	8
X-5	1	12,05	43,70	0,31	1	360	360	18

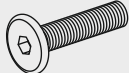
Accessories List

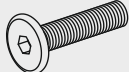
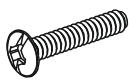
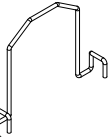
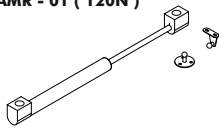
<p>MXN 02</p>  <p>46 / piece</p> <p>TFC - 01 (8x70) mm</p>	<p>MNG - 01</p>  <p>46 / piece</p> <p>DSE - 01 (40x90x32) mm</p>  <p>4 / piece</p> <p>VDA - 01 (6,5x50) mm</p>  <p>4 / piece</p> <p>AVT - 01</p>  <p>7 / piece</p> <p>TSY - 01</p>  <p>2 / piece</p> <p>CT - 03 (6x50) mm</p>  <p>10/ piece</p> <p>KP - 01 (128) mm</p>  <p>5 / piece</p> <p>SC - 76</p>  <p>2 / piece</p> <p>TVM - 01</p>  <p>1 / piece</p>	<p>KVL 01</p>  <p>48 / piece</p> <p>VTB - 01 (4,8x16) mm</p>  <p>24 / piece</p> <p>TAP - 02</p>  <p>4 / piece</p> <p>IM - 01 (6x30) mm</p>  <p>4 / piece</p> <p>VD - 03 (3,5x18) mm</p>  <p>30 / piece</p> <p>CT - 04 (6x20) mm</p>  <p>8 / piece</p> <p>VKP - 01 (22) mm</p>  <p>10 / piece</p> <p>H 01</p>  <p>2 / piece</p> <p>KKS - 01</p>  <p>2 / piece</p>	<p>TAP - 01</p>  <p>46 / piece</p> <p>PL - 02 (8x22x1) mm</p>  <p>4 / piece</p> <p>OT-054</p>  <p>2 / piece</p> <p>CT - 01 (6x40) mm</p>  <p>2 / piece</p> <p>PM - 01</p>  <p>20 / piece</p> <p>CT - 05 (6x35) mm</p>  <p>4 / piece</p> <p>VKP - 03 (40) mm</p>  <p>4 / piece</p> <p>TTC 01</p>  <p>4 / piece</p>
<p>AMR - 01 (120N)</p>  <p>1 / piece</p>			

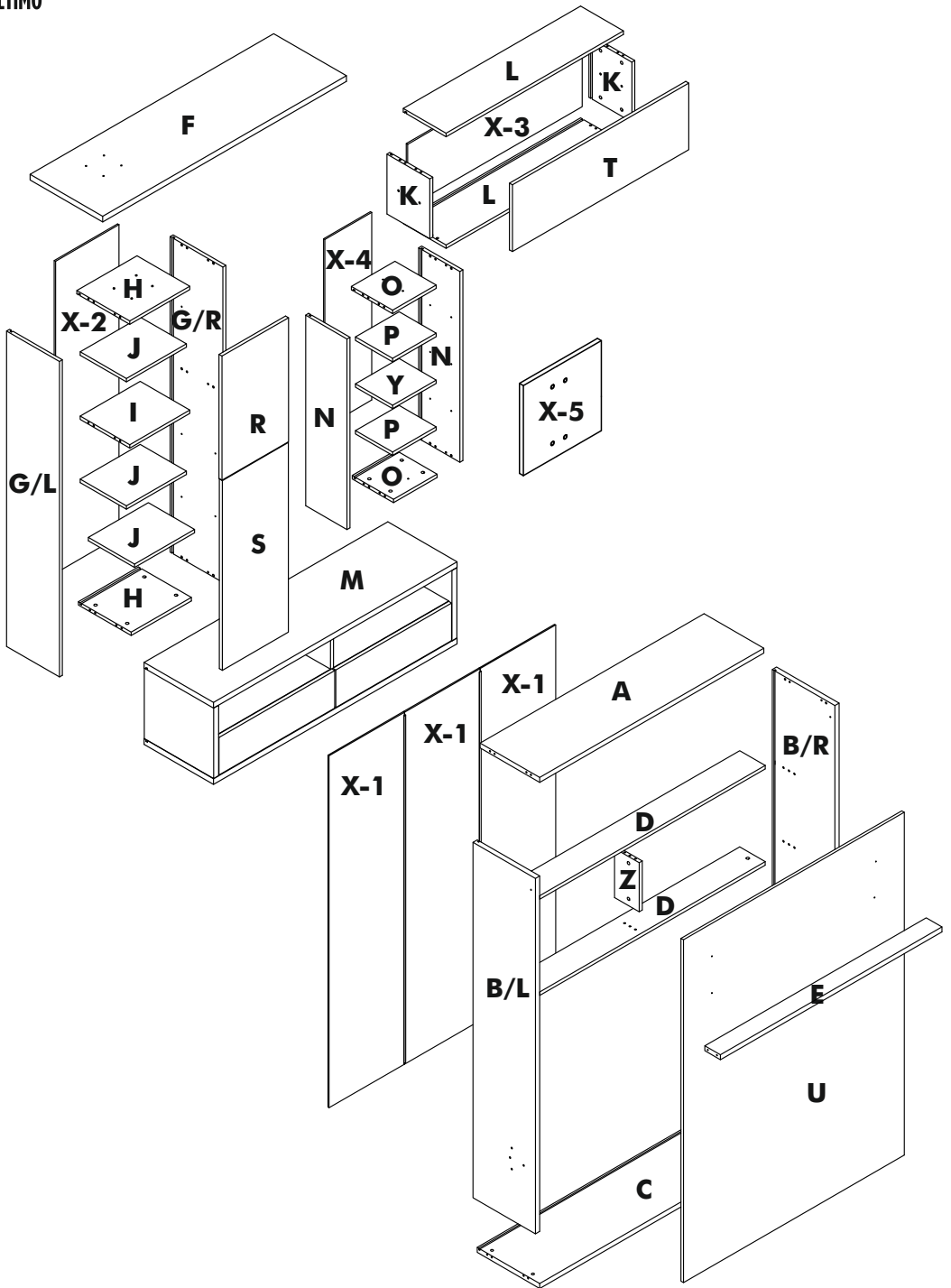

STEP 1



MNX - 02

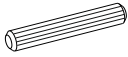

KVL 01

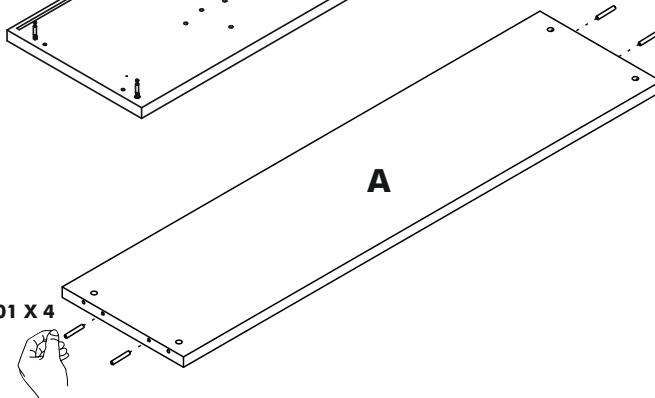
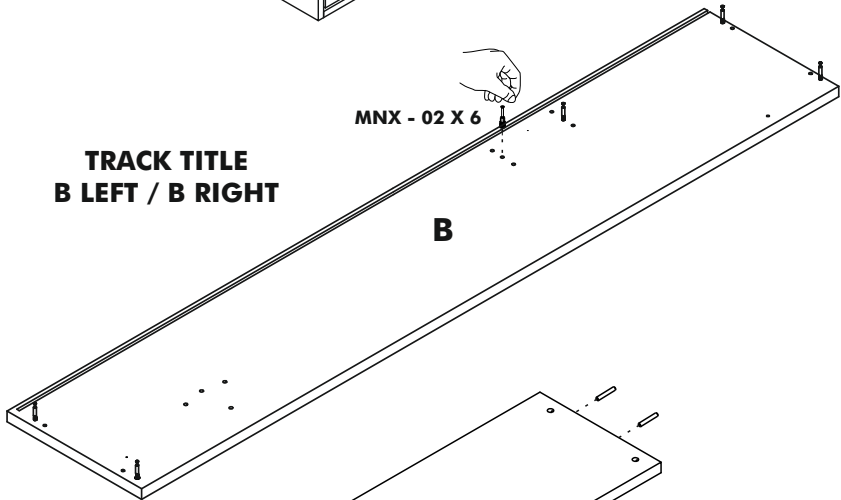
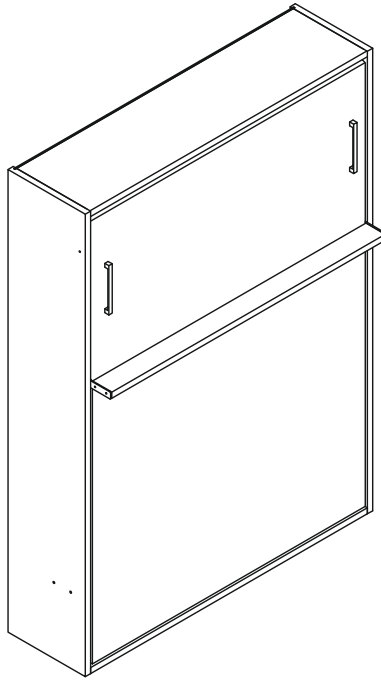

VIDEO

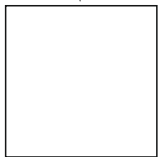

link

STEP 2

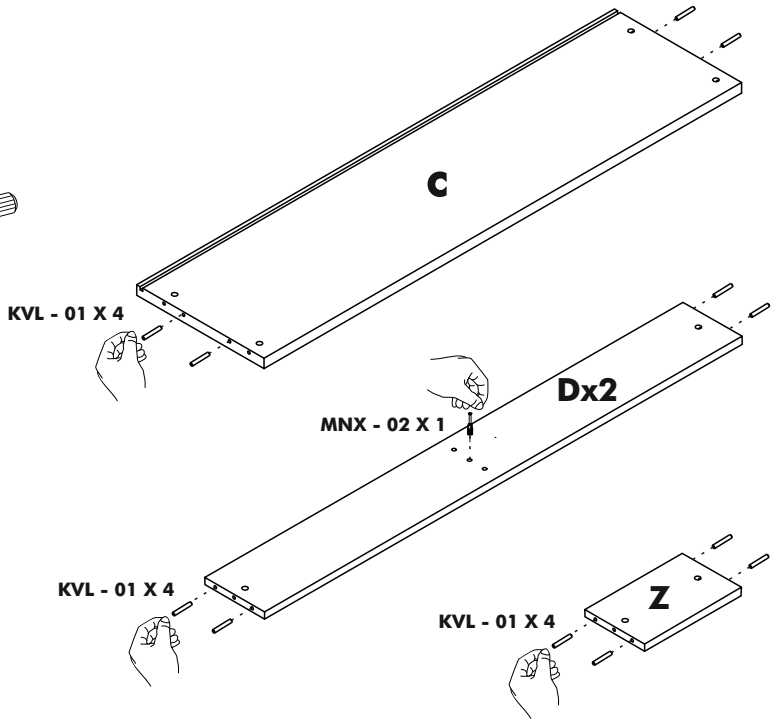

STEP 3

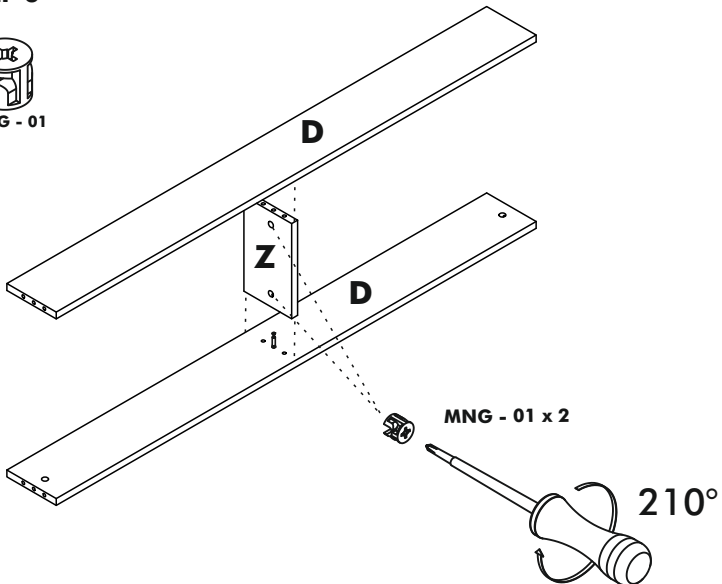

VIDEO

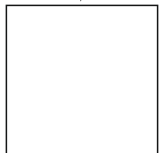

link

STEP 4

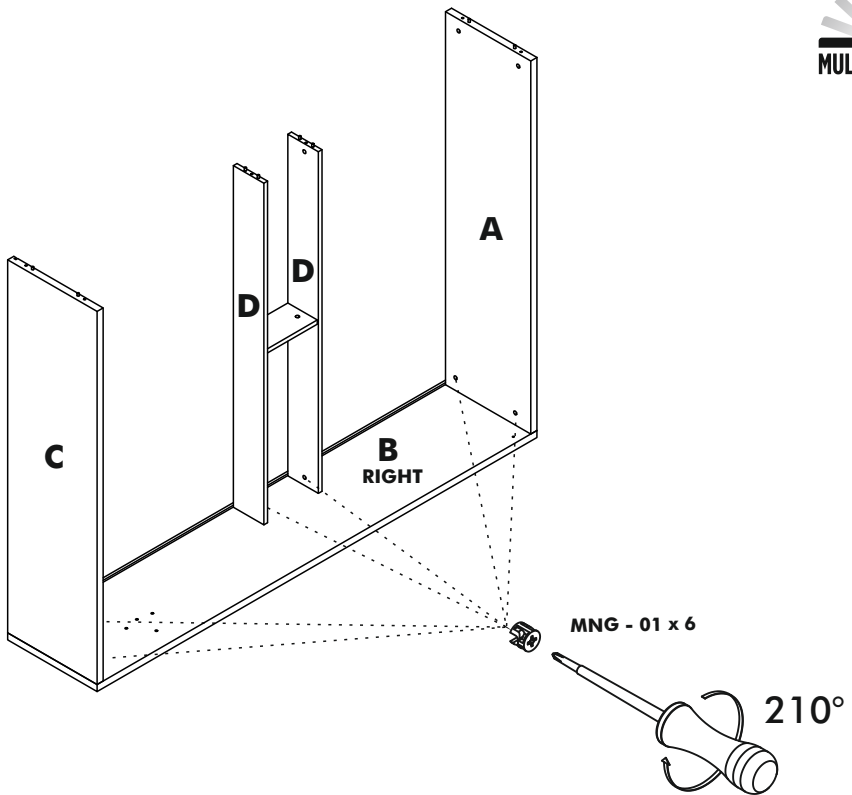

STEP 5

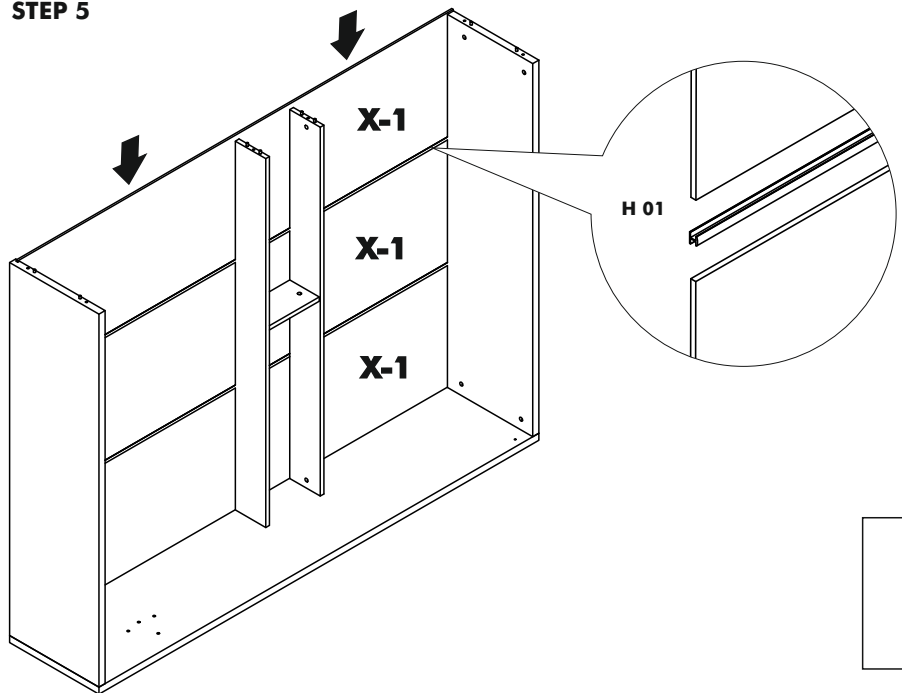

STEP 6

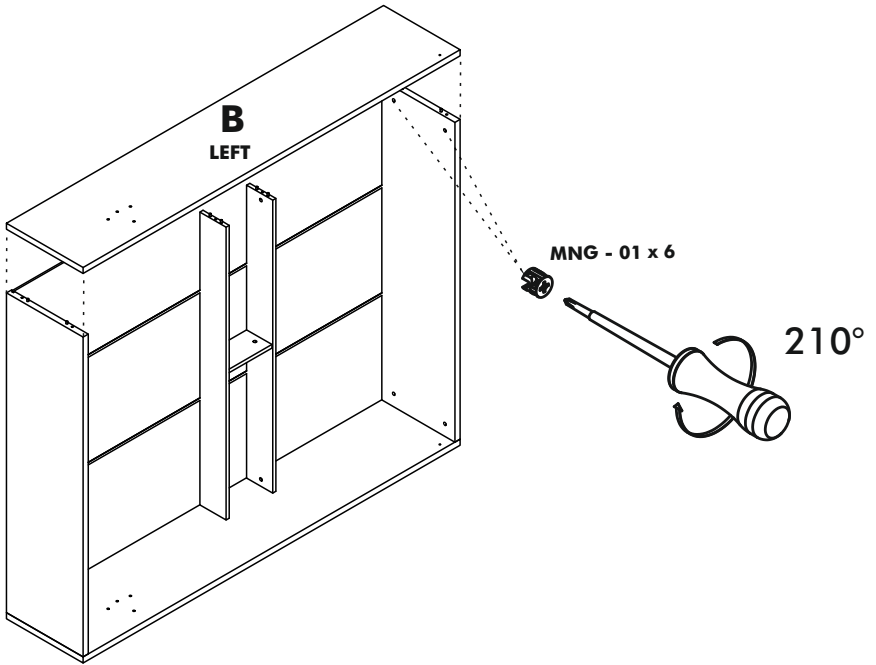

STEP 7

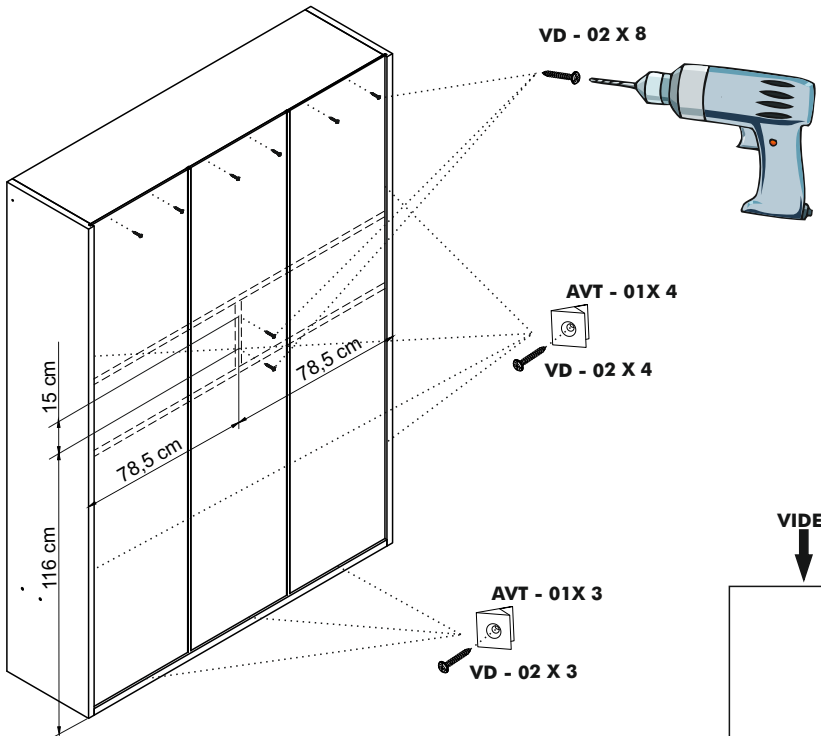

VIDEO

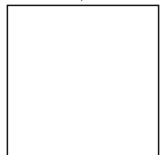

link

STEP 8

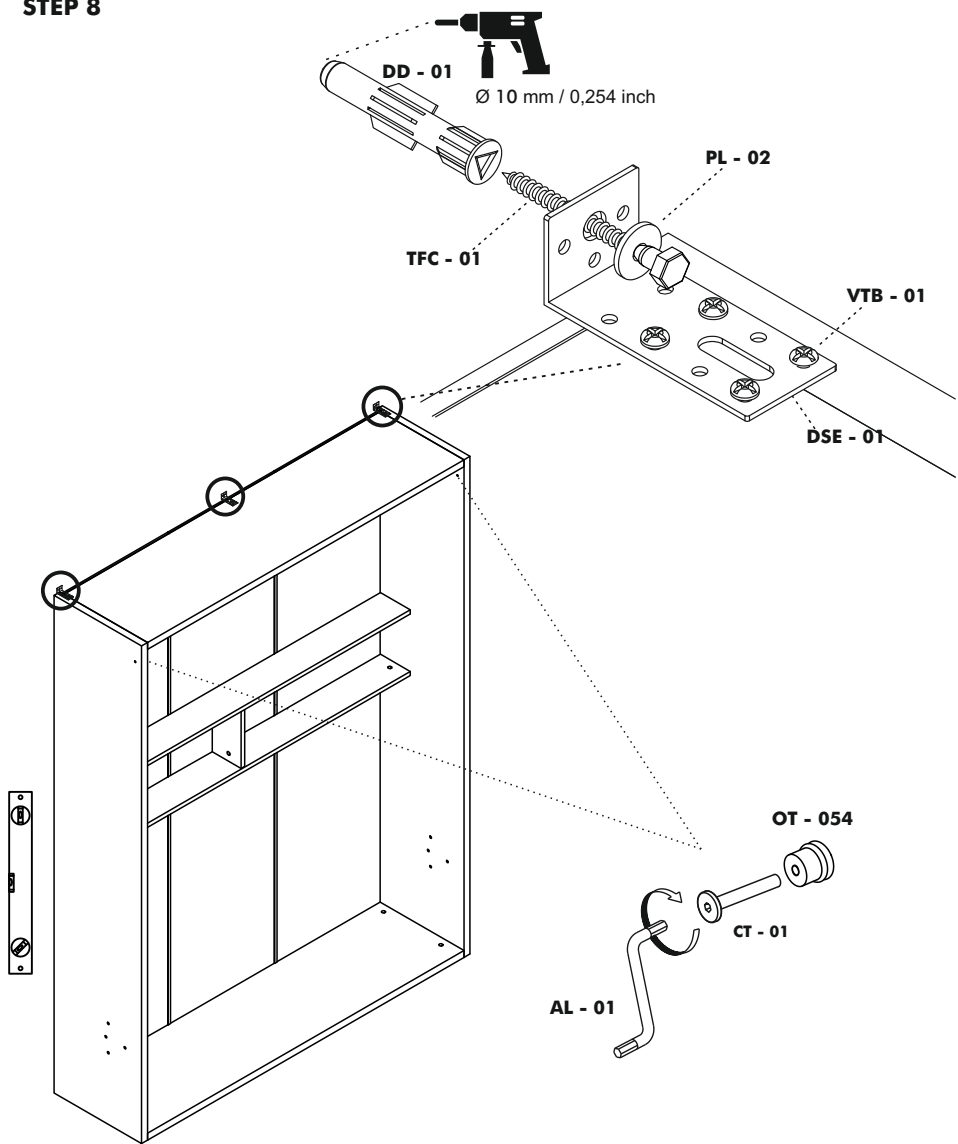

VIDEO

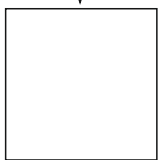

link

STEP 9

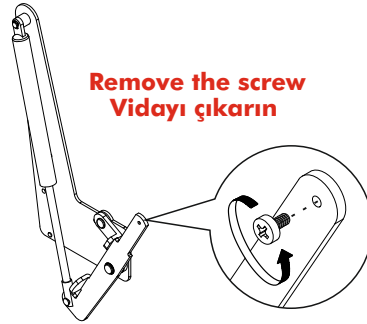

CAUTION
DO NOT UNLOCK
BEFORE INSTALL

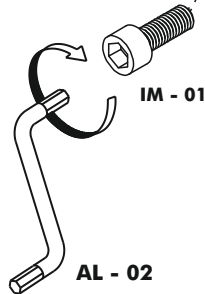
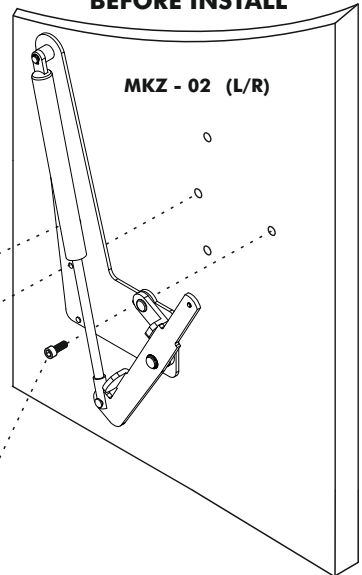
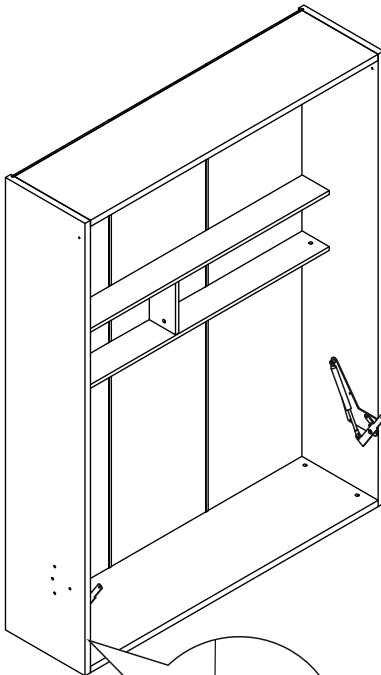

VIDEO

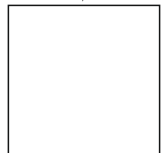

link

STEP 10

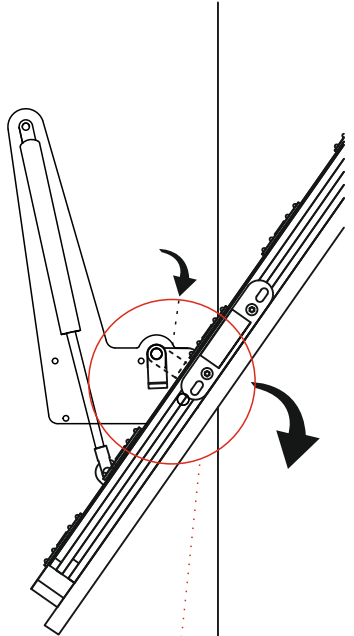
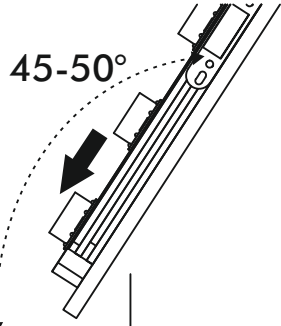
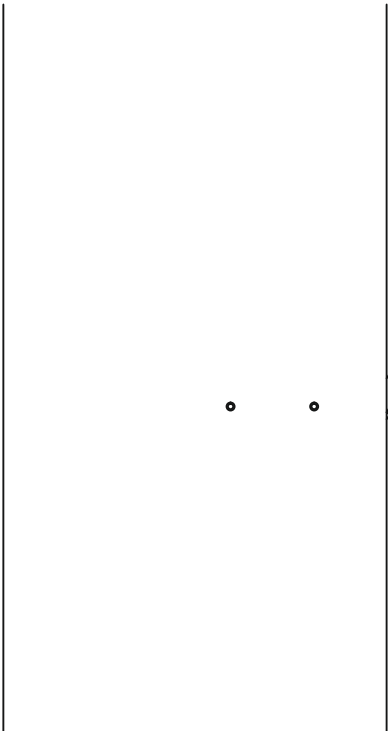

**KAPAK KAPATILMADAN KİLİDİ İNDİRİN !!!
LET THE STOPPER LOCK MOVE DOWN !!!**

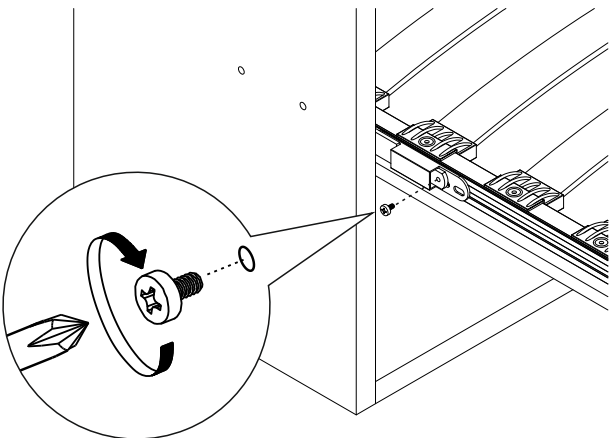
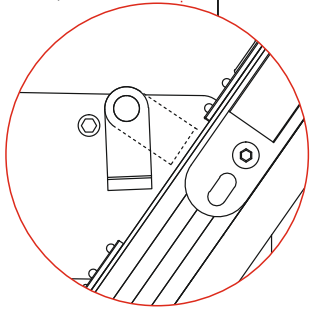

VIDEO

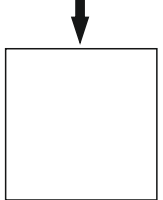

link

STEP 11

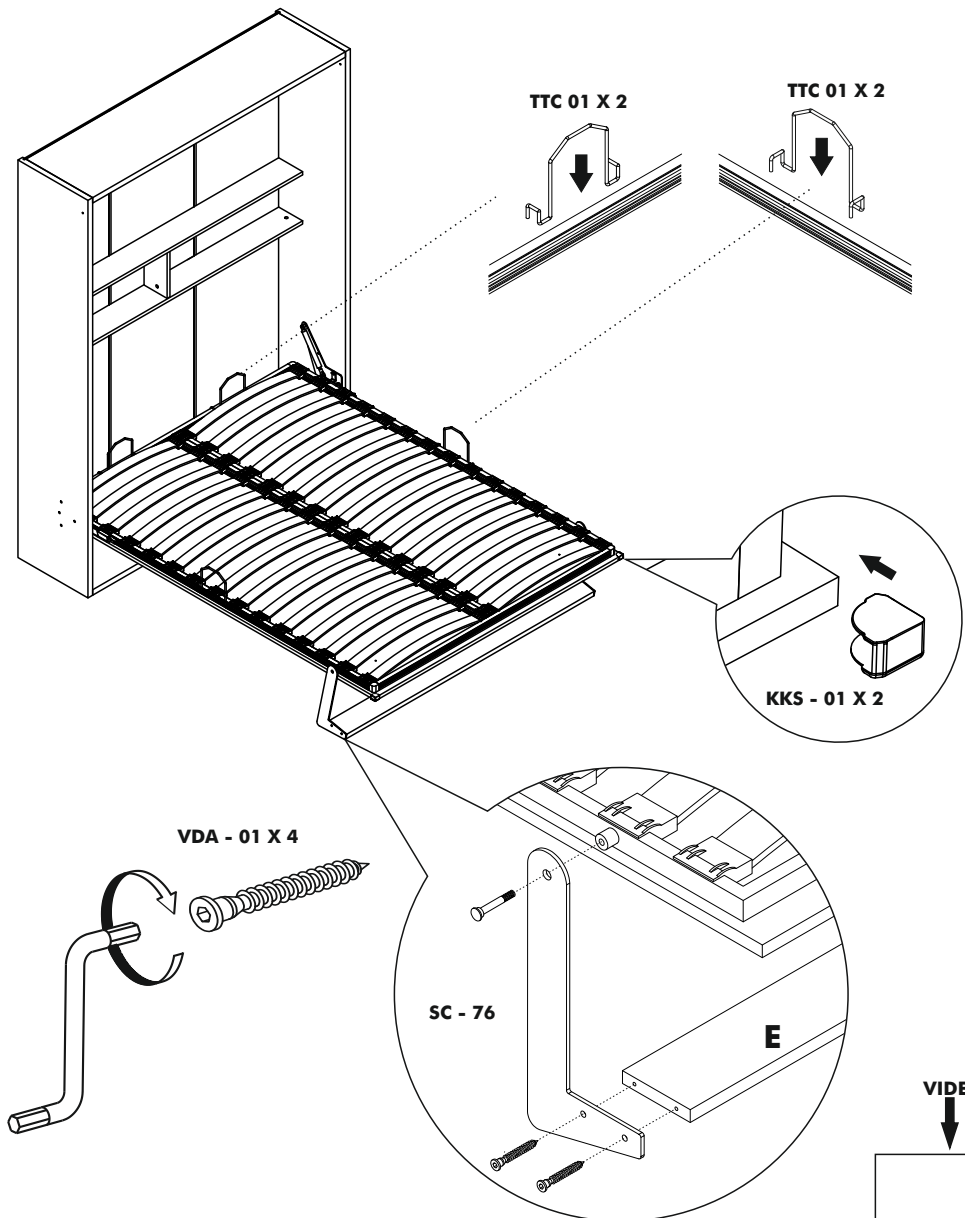

STEP 12

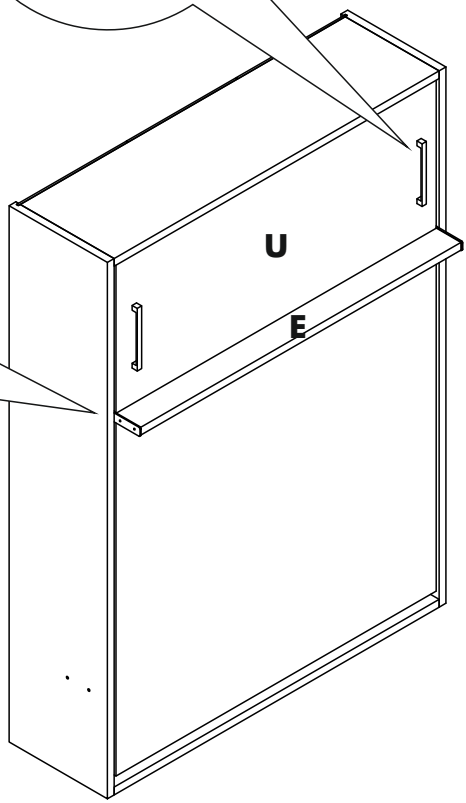
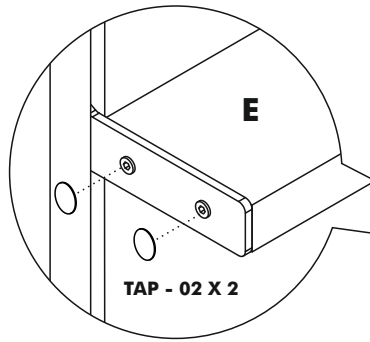
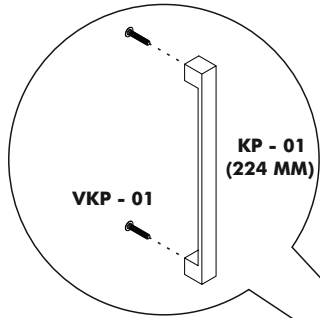

VIDEO



link

STEP 13

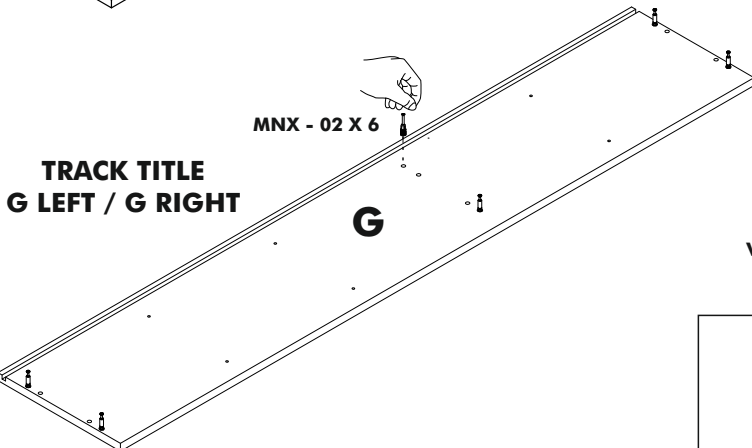
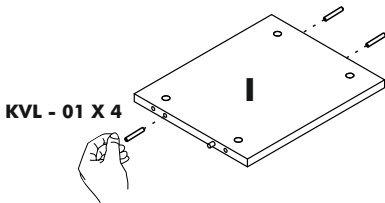
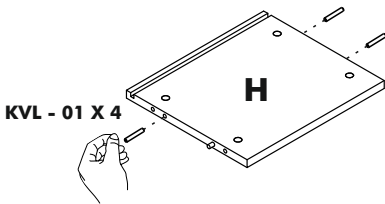
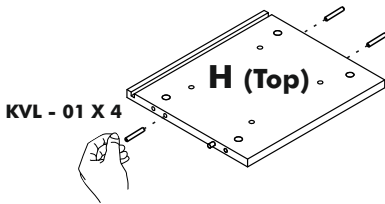
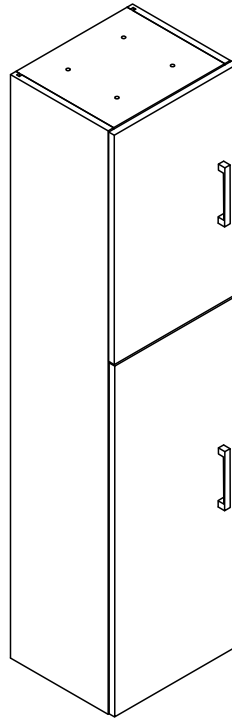
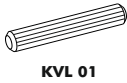
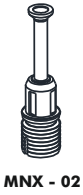

VIDEO

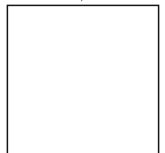

link

STEP 14

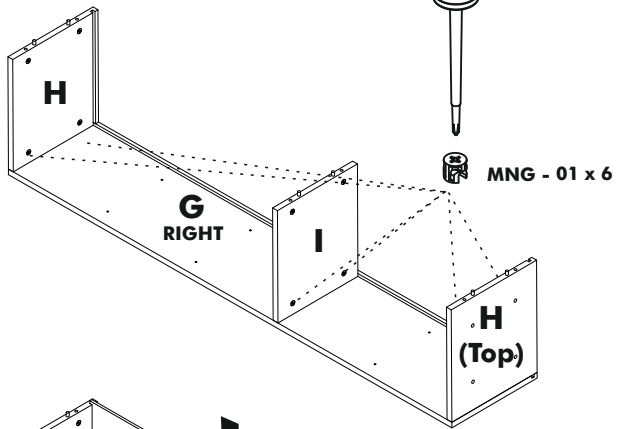
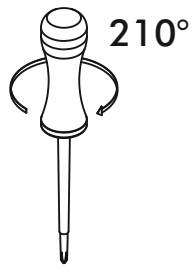

STEP 15

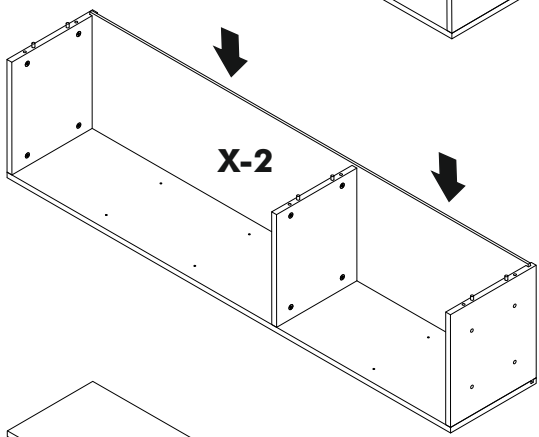

STEP 16

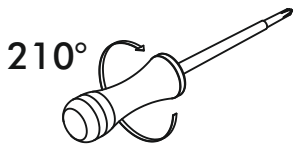
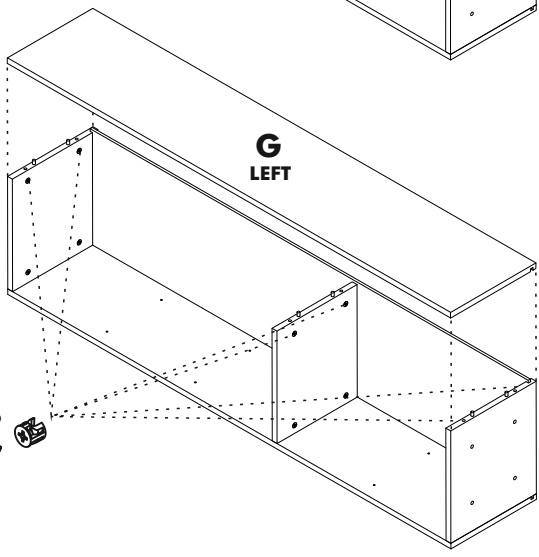

VIDEO
↓

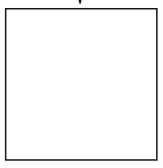

link

STEP 17

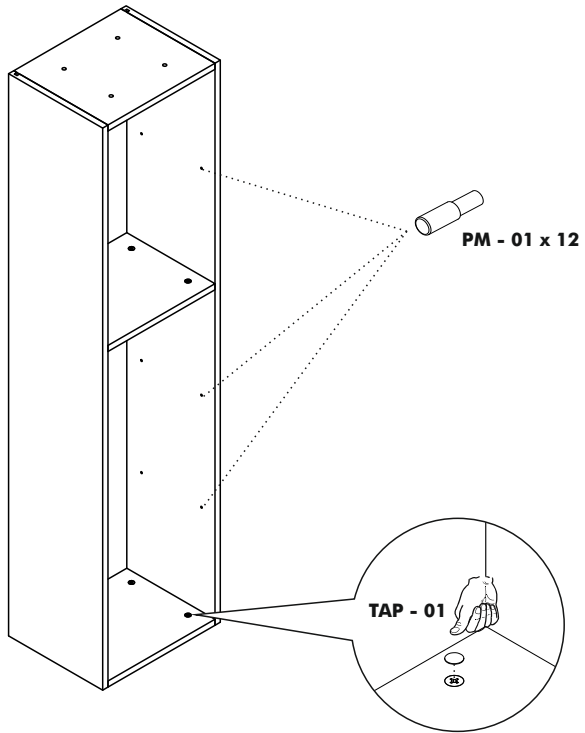

STEP 18

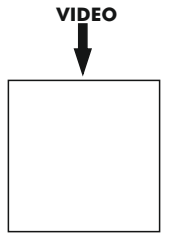
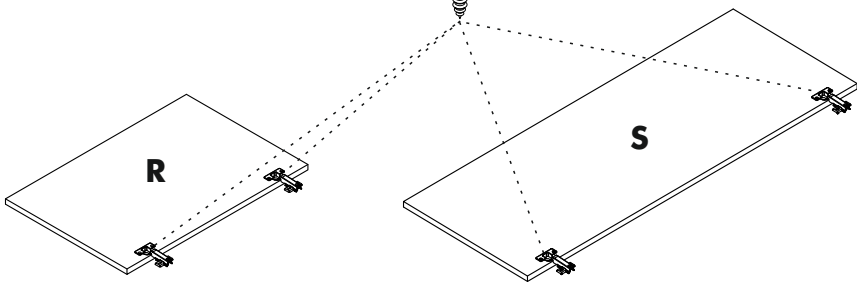
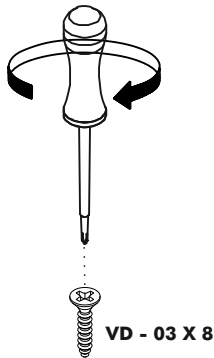
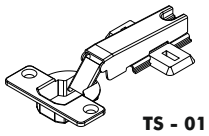

STEP 19

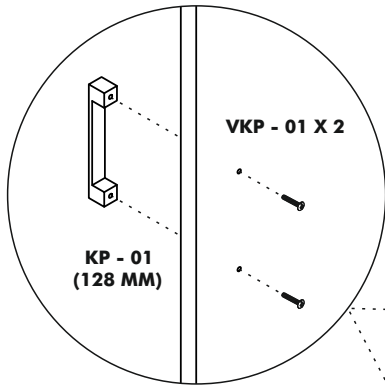

STEP 20

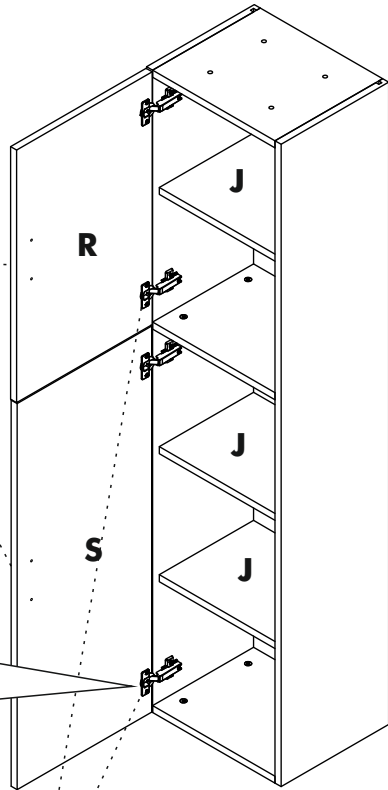
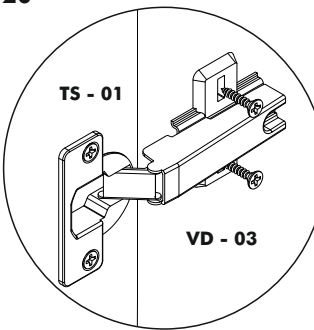

TSY- 01 x 2

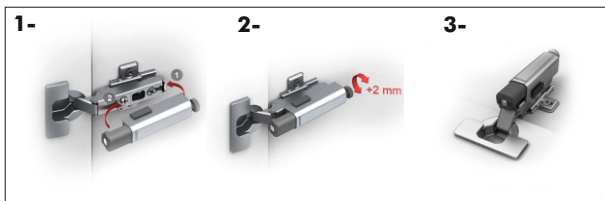

VIDEO

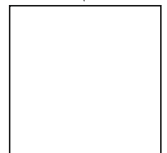

link

STEP 21



MNX - 02

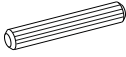

KVL 01

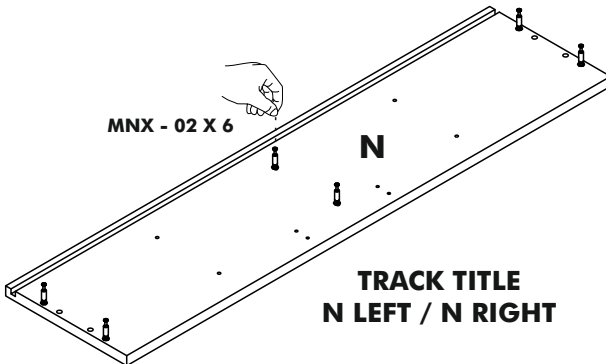
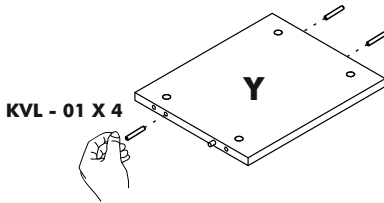
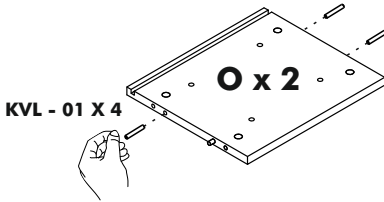
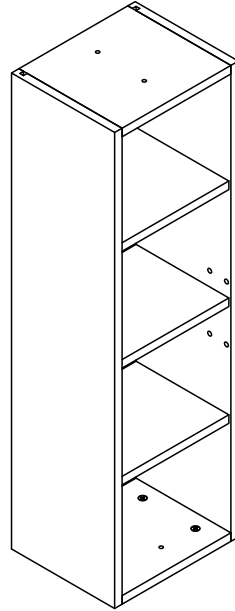

VIDEO

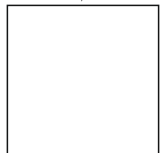

link

STEP 22

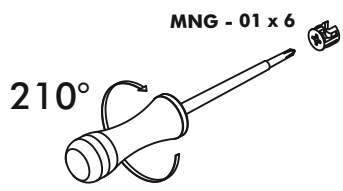
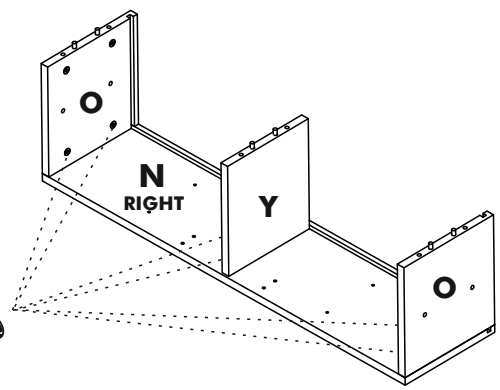

STEP 23

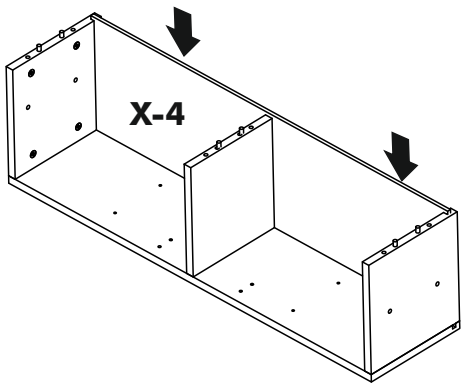

STEP 24

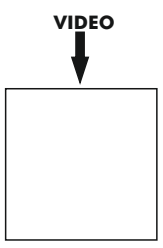
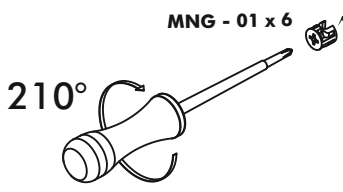
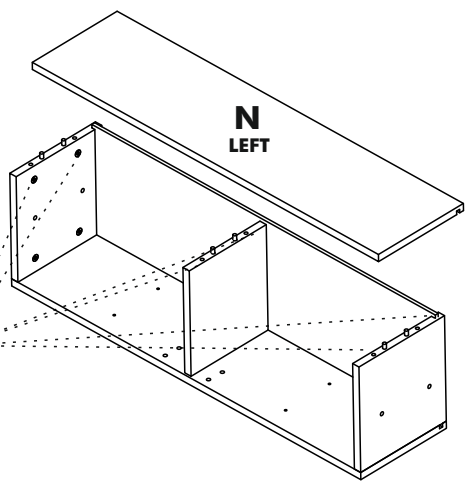

STEP 25

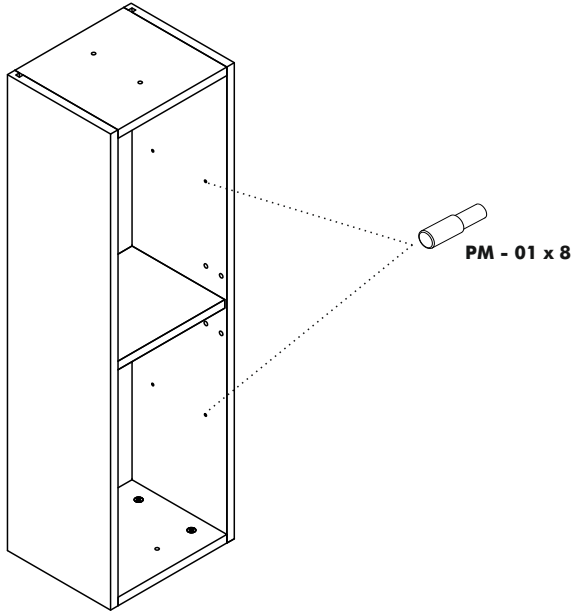

STEP 26

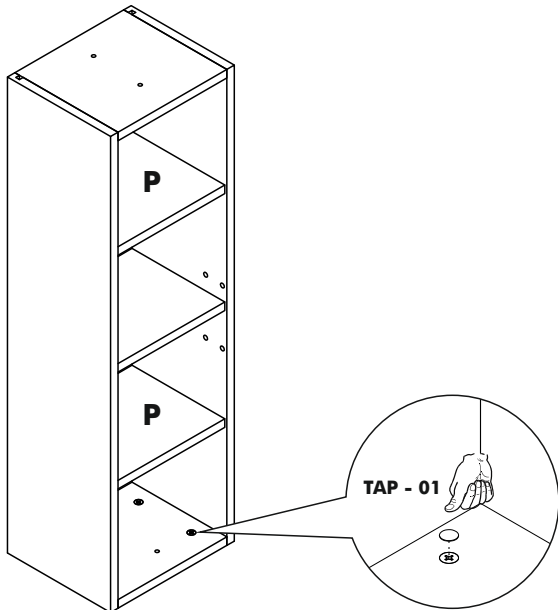

STEP 27

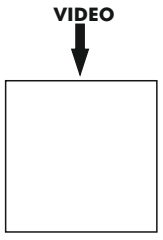
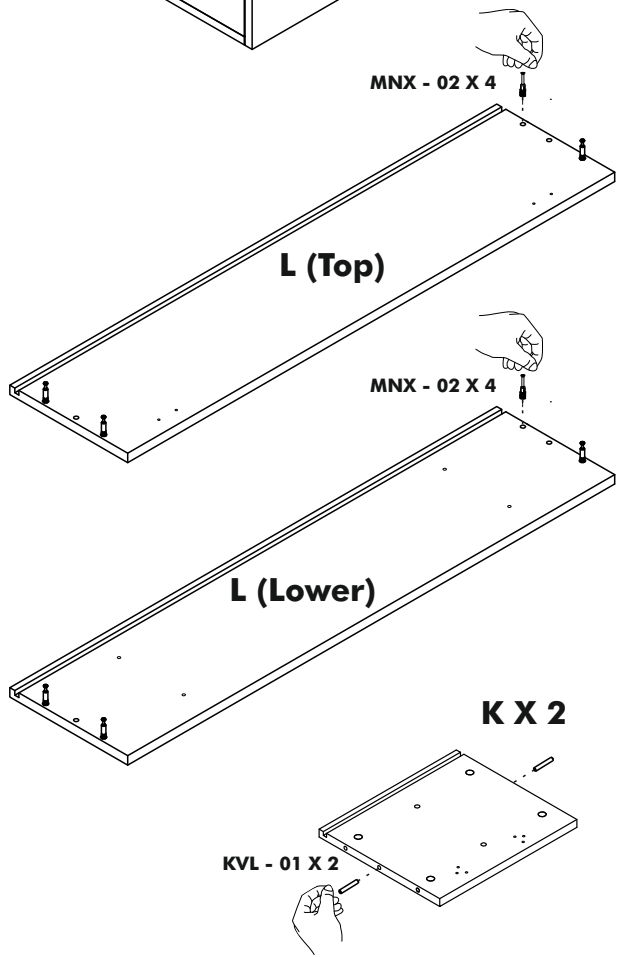
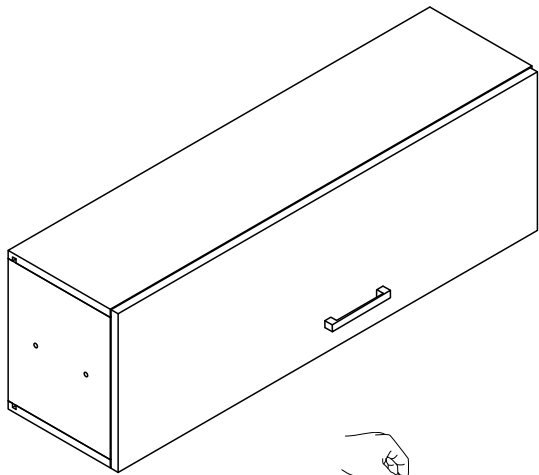
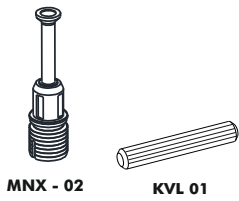

STEP 28



MNG - 01

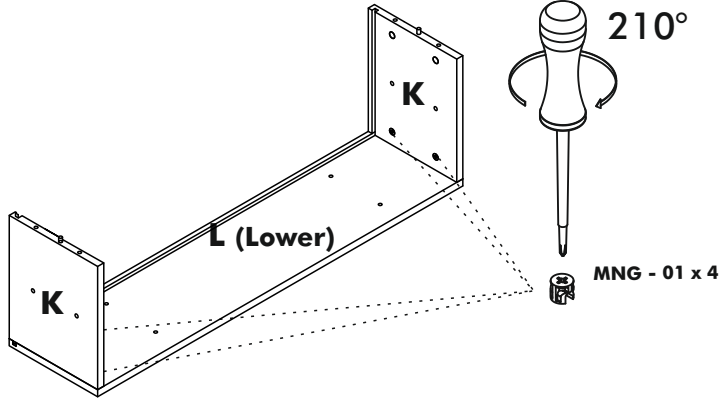

STEP 29

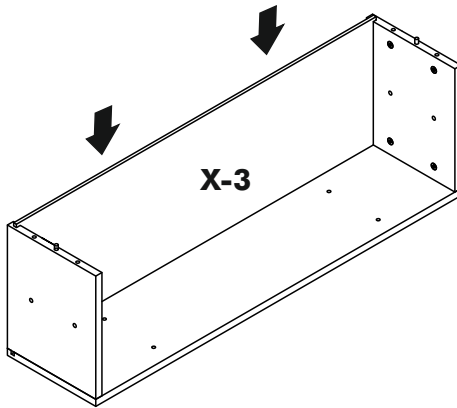

STEP 30



MNG - 01

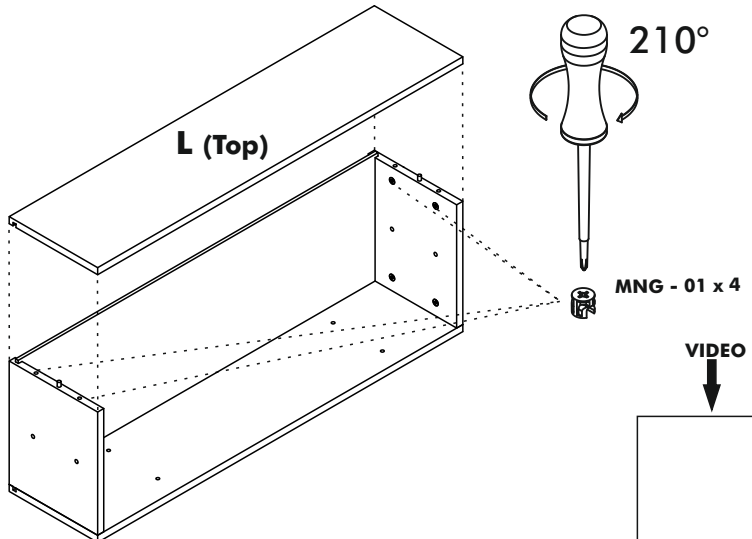

STEP 31

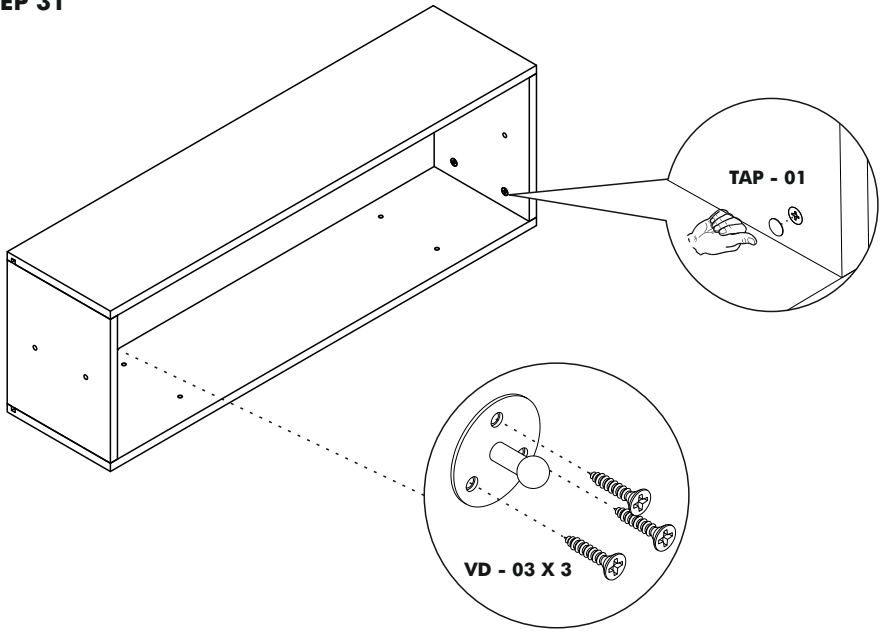

STEP 32

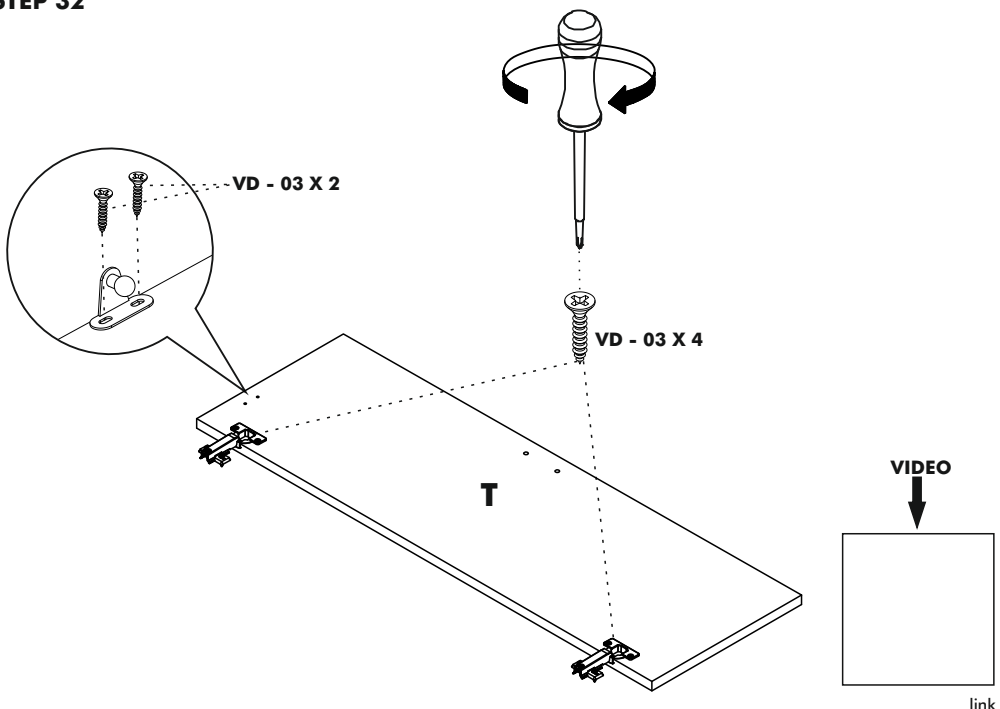

STEP 33

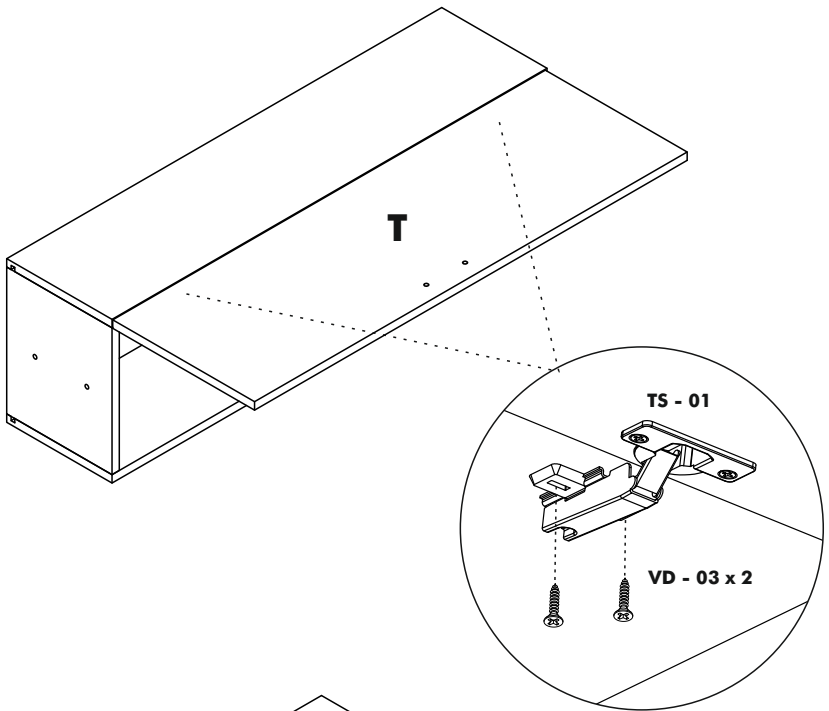

STEP 34

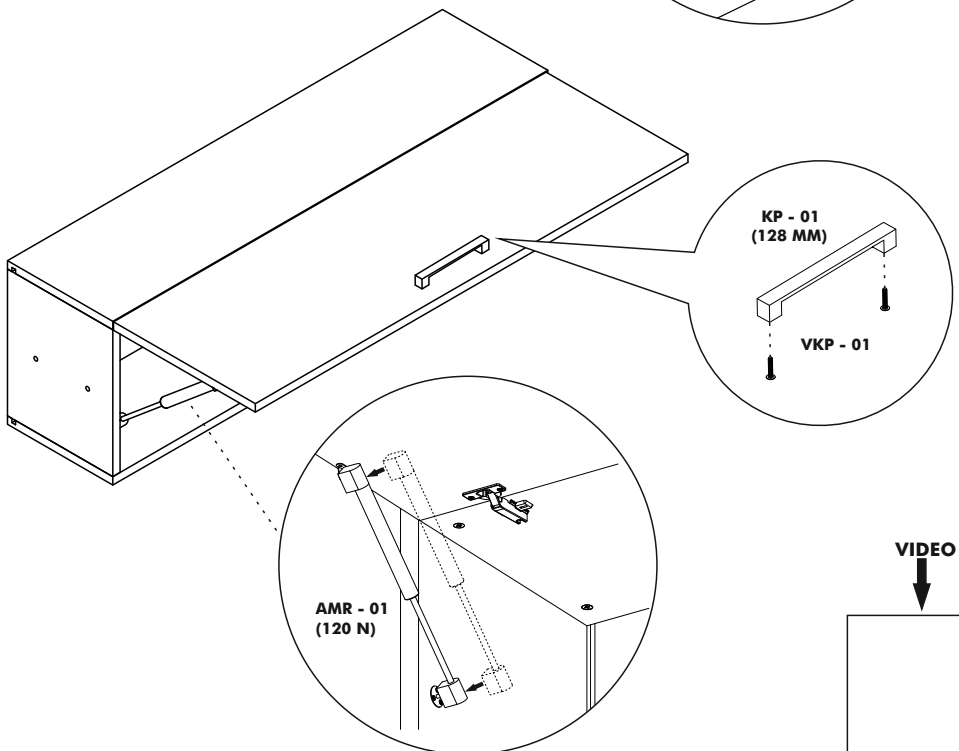

VIDEO

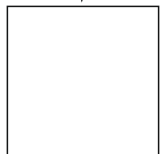

link

STEP 35

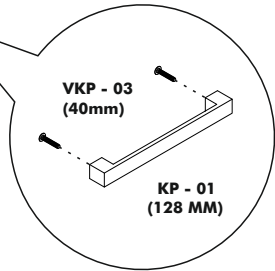
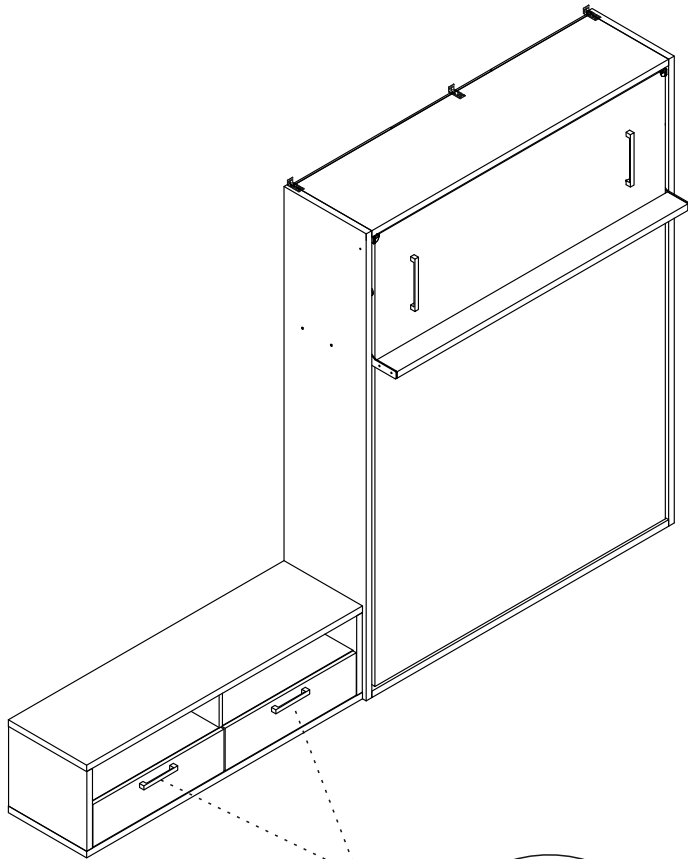

VIDEO

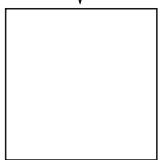

link

STEP 36

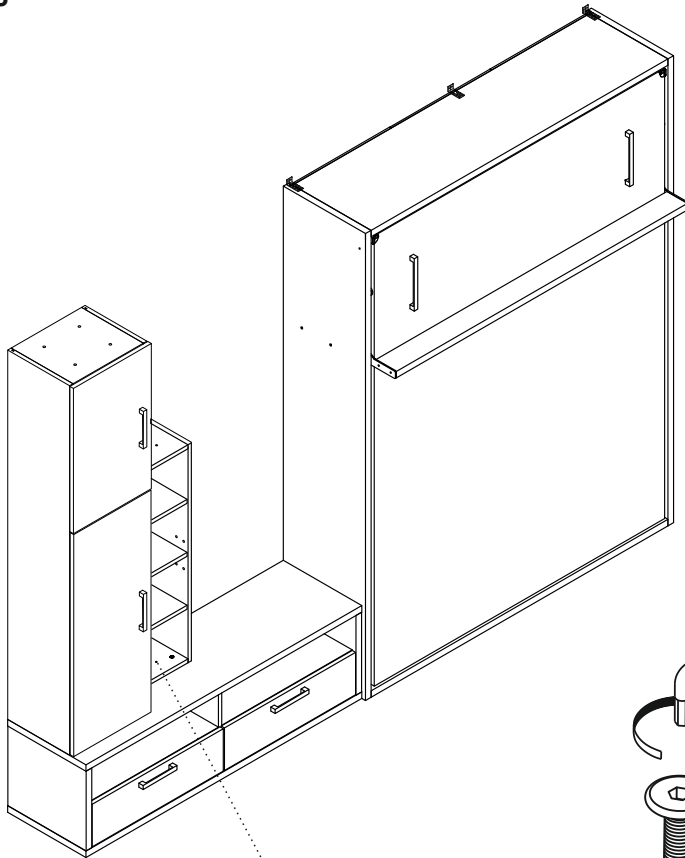

AL - 01

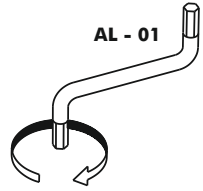

CT - 03 X 2

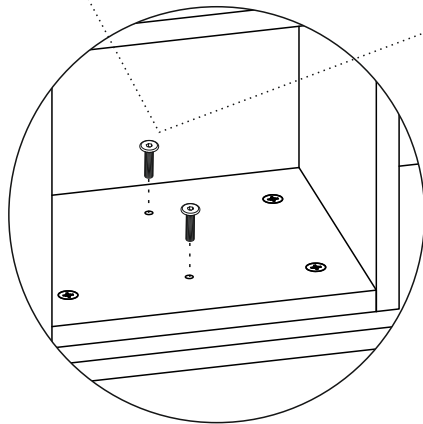
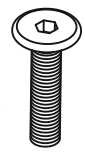

VIDEO

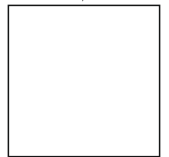

link

STEP 37

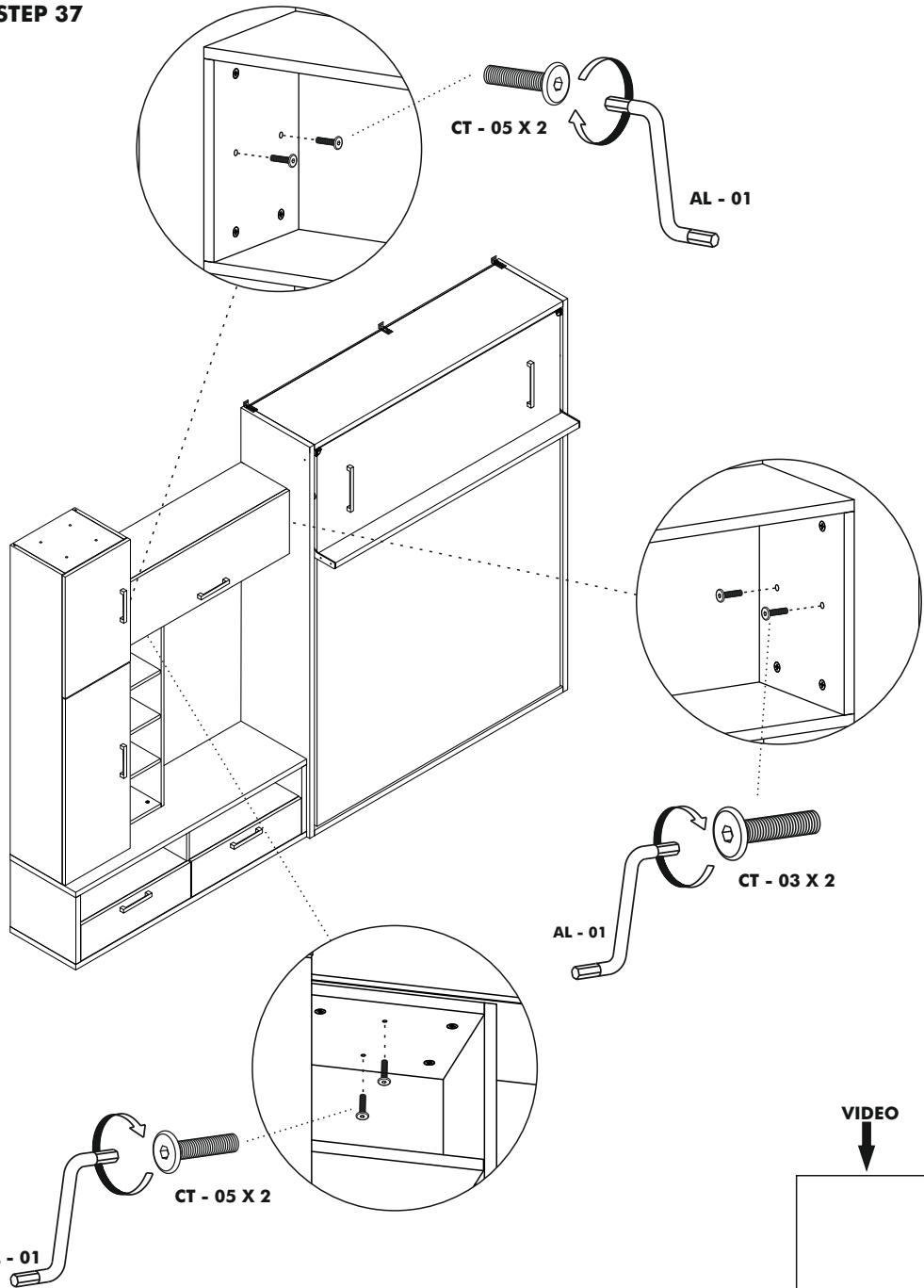

CT - 05 X 2

AL - 01

CT - 03 X 2

AL - 01

CT - 05 X 2

AL - 01

VIDEO

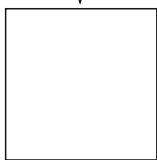

link

STEP 38

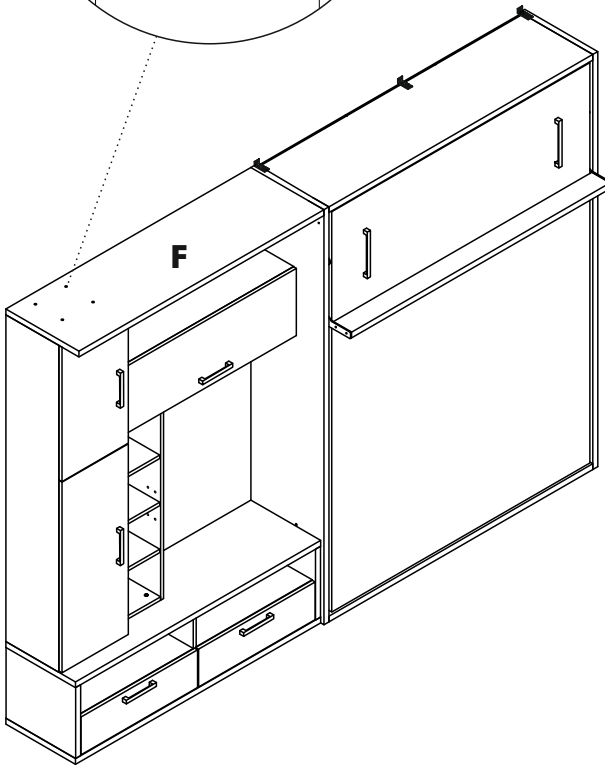
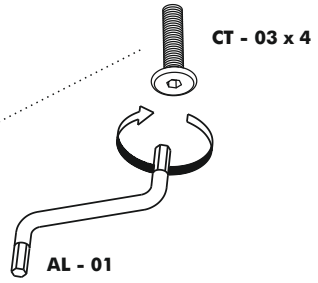
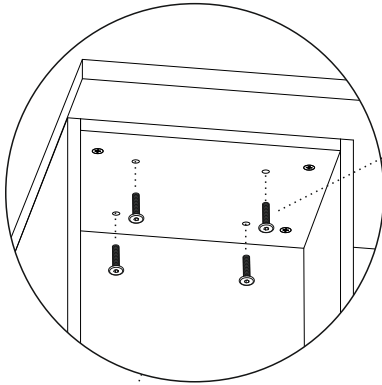

VIDEO

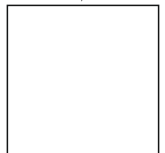

link

STEP 39

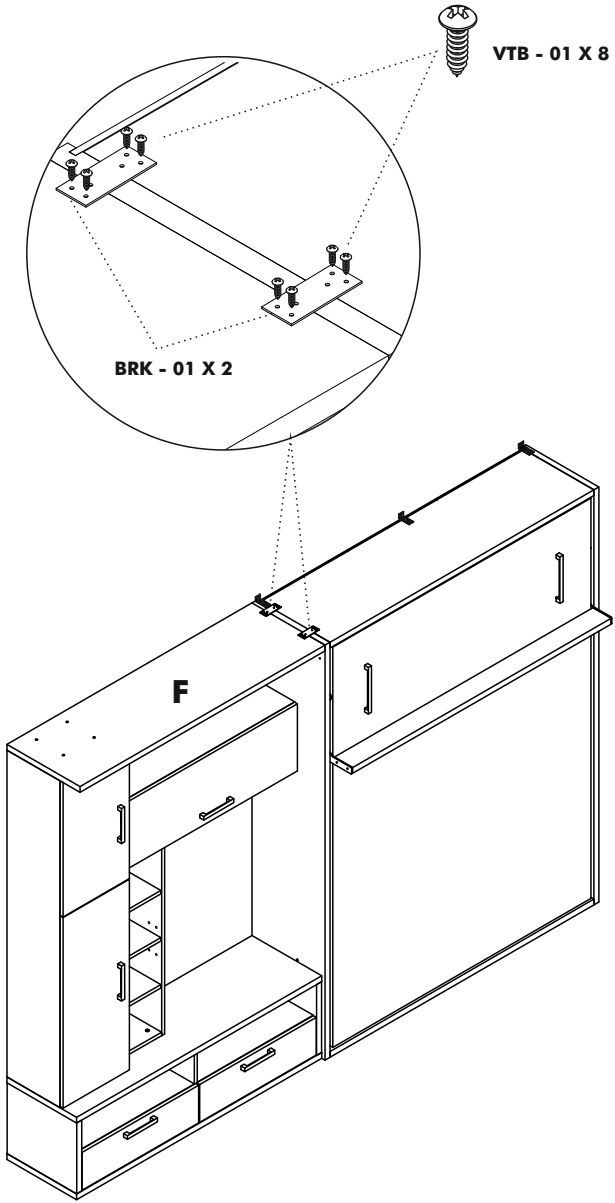

VIDEO

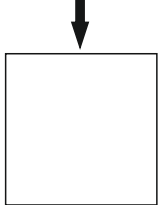

link

STEP 40

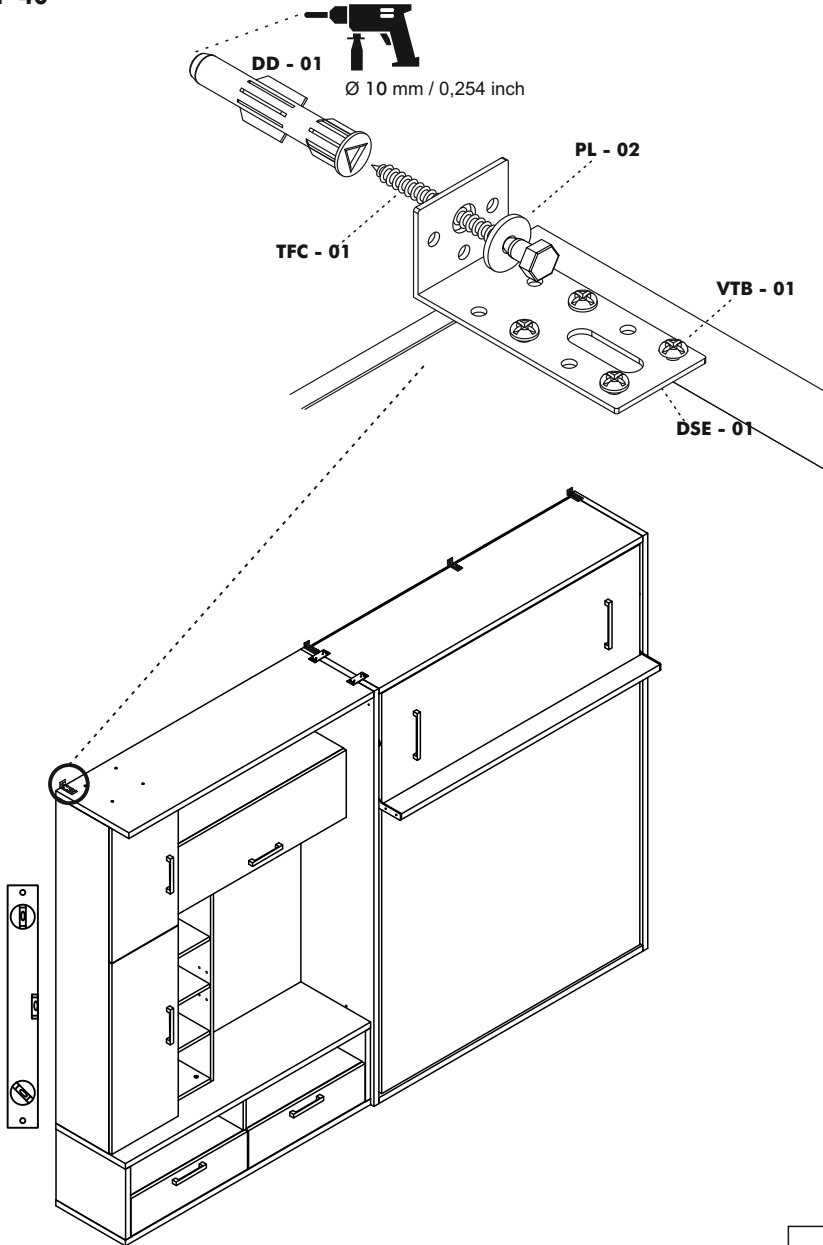

VIDEO

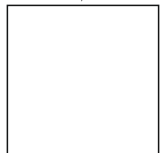

link

STEP 41

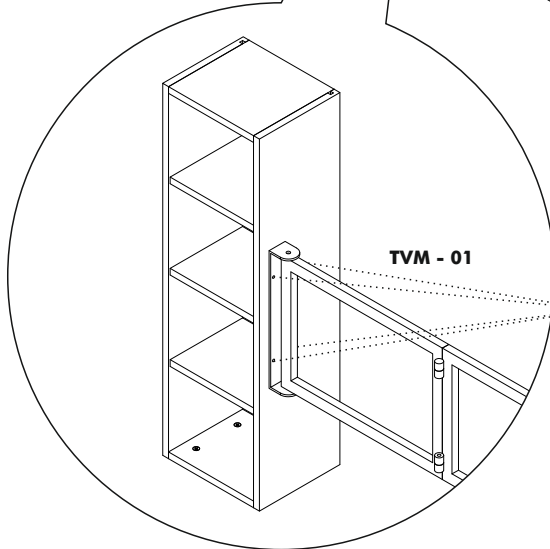
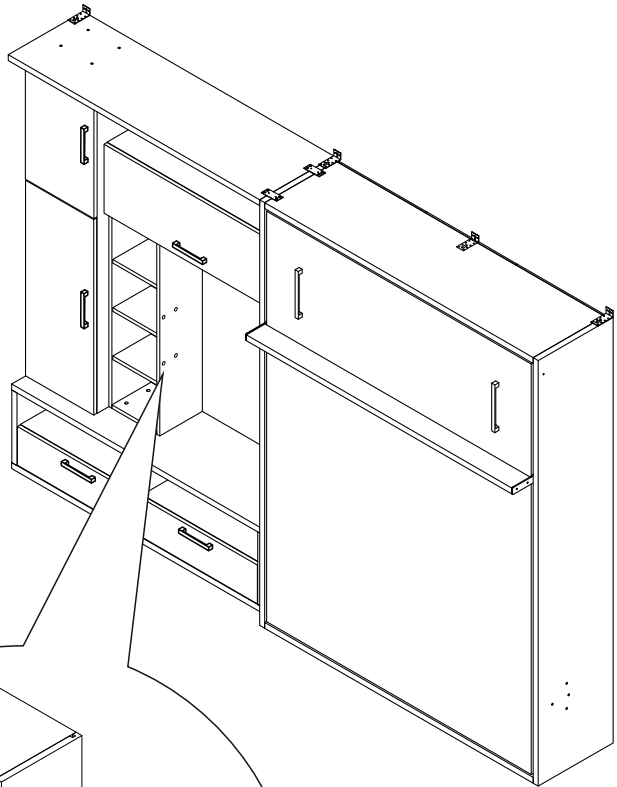

TVM - 01

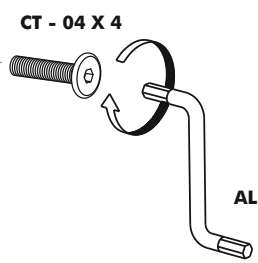

CT - 04 X 4

AL - 01

VIDEO

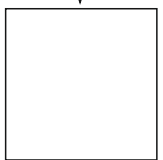

link

STEP 42

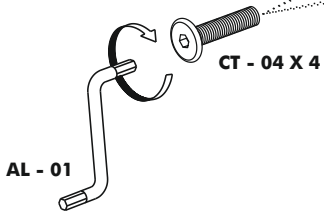
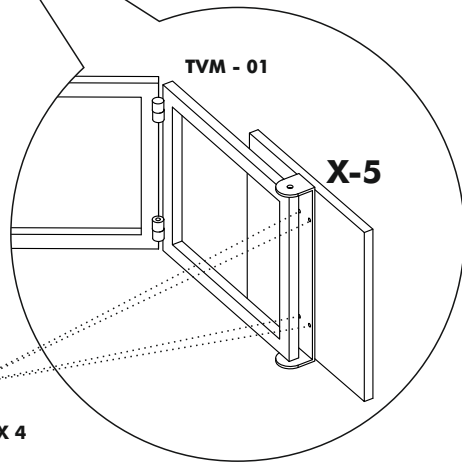
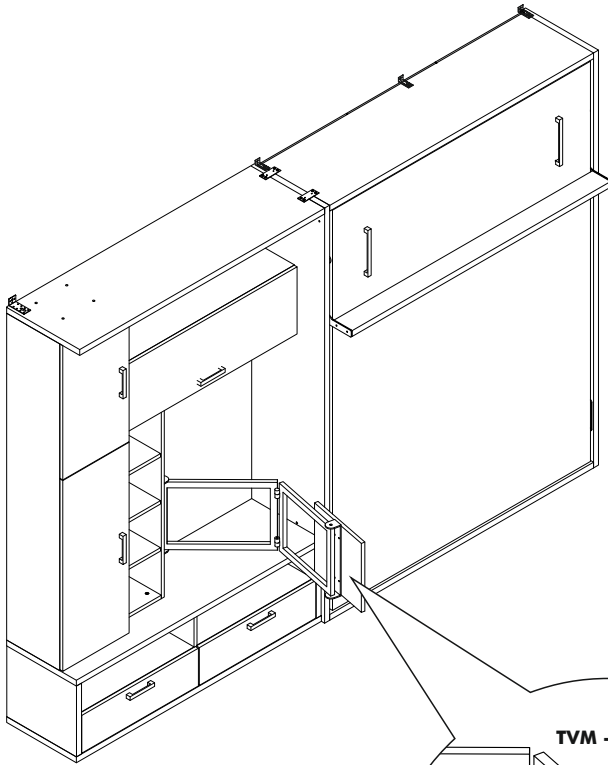

VIDEO

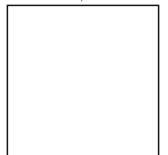

link

STEP 43

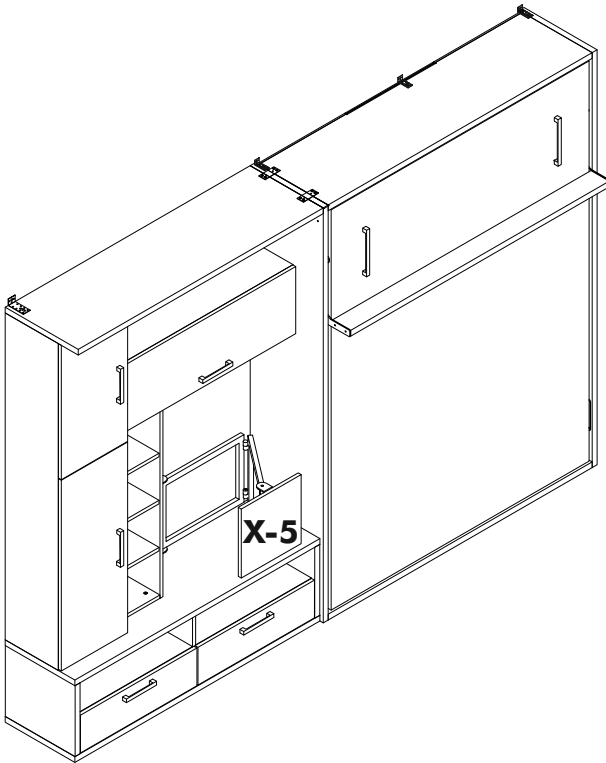

VIDEO



link

STEP 44

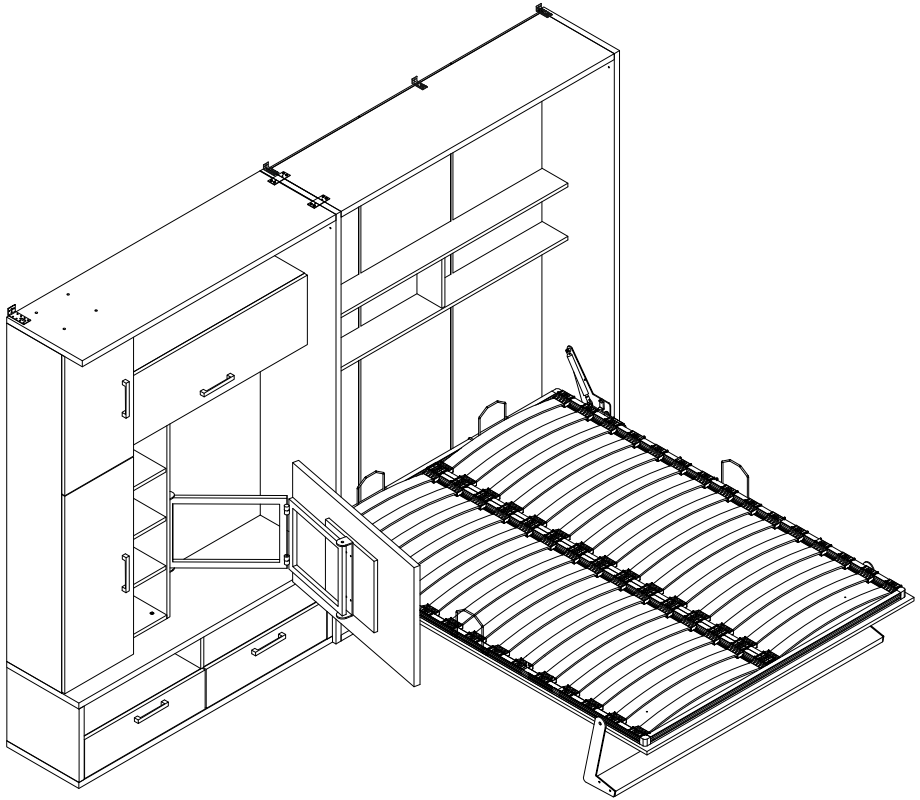

VIDEO

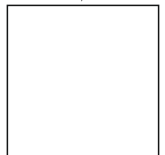

link

ATTENTION / HOW TO / READ ME / OWNER'S GUIDE

1. When mounting on a regular drywall, furniture must be fastened to wood or metal studs. Solid walls made of brick, concrete or similar strong material are also acceptable. Do not mount furniture to paper-mache or sheetrock (plasterboard) like material without properly fixing to stud.

2. For safety and product longevity you must periodically inspect the mounting and mechanical connections for integrity and tightness. Confirm hardware remains properly affixed and connections snug.

3. Wall Bed mattress thickness may not exceed 8 inches (200mm). Take care to remove pillows and excess blankets before closing. Doing so keeps mechanism free of obstruction and unnecessary stress.

4. Do not lean or rest heavy objects on side or top of furniture. This may cause balance issues and compromise the integrity of your mounting connections.

5. Please use the furniture's beds, desks and shelving as intended. Not designed to be sat, stood, leaned, jumped (etc) on. Improper use may cause personal injury and damage to property.

6. With seasonal humidity change you must inspect interior and exterior of furniture.

7. Single bed models are suitable for the weight of one person. Sleeping by more than one person will cause damage of the product.

8. Before any un-mounting or disassembly please contact Multimo for technical support and instruction. Failure to properly detach risks injury to person and damage to property.

9. For Bunk Beds:

- a. Always use provided ladder when accessing top bunk.
- b. Be slow, careful and aware of surroundings when opening top bunk.
- c. Do not horseplay. Beds are to be slept on only.
- d. Some have legs that fully extend when open- be aware of where the leg is and will be.



MULTiMO

www.multimo.com